

# Block Watch

Captain, Co-Captain & Block Watch Participant Manual



**Block Watch**<sup>®</sup>  
[www.blockwatch.com](http://www.blockwatch.com)

**An operation manual for  
the Block Watch Program**

*For Safer Communities*

# Contents

---

<b>Why Block Watch?</b> .....	<b>3</b>
<b>Block Watch Program Overview</b> .....	<b>4</b>
<b>Running Block Watch</b> .....	<b>5</b>
<b>Captain &amp; Co-Captain Responsibilities</b> .....	<b>6</b>
<b>The Block Watch Map</b> .....	<b>7</b>
<b>Program Dynamics</b> .....	<b>8</b>
<b>Safer Communities</b> .....	<b>9</b>
<b>Holding a Block Watch Meeting</b> .....	<b>10</b>
<b>Maintaining Block Watch</b> .....	<b>12</b>
<b>Dwellings Other Than Houses</b> .....	<b>13</b>
<b>Property Identification</b> .....	<b>14</b>
<b>Home Security Tips</b> .....	<b>15</b>
<b>Property Inventory Chart</b> .....	<b>18</b>
<b>Suspect Identification</b> .....	<b>20</b>
<b>Participant List</b> .....	<b>21</b>

# Why Block Watch?

---

In recent decades, policing has changed dramatically. Historically, police have used a reactive style of law enforcement. In other words, they responded to your complaints. A growing population, budget cuts, and other factors have forced them to rely on you, the public, more than ever. Consequently, community policing has arrived. The police are establishing a base within communities in an effort to fight crime on an altogether different level.

In 1986, this model of community policing led to the development of Block Watch. Block Watch works out of your local police department or community police office. Its personnel usually consists of one coordinator, which may be a police officer or a civilian, and in some offices, one or more assistant coordinators.

Your Block Watch office is not always able to have direct contact with the general duty or burglary section members of the police force. Therefore, the Block Watch Office may be unaware if a break-in occurs on your block. So, communication between you and the office is of utmost importance. **We need to hear from you!** Participation in the program is the key to its success.

The program has been influential in arresting criminals and, in general, reducing crime. It also promotes increased feelings of neighbourhood security.

---

## Congratulations on Volunteering...

### Every successful program needs leaders like you!

- Block Watch is a way to have neighbours watch and communicate with each other and Police.
- Block Watch involves being alert.
- Block Watch involves being aware of your neighbour's property as you would your own, and a commitment to reporting suspicious activity to your police and neighbours.
- Your involvement and leadership is the key to success.



# Block Watch Program Overview

## What Block Watch Is

**Block Watch is an extension** of what you may already be doing on a daily basis. Many of us have watched our neighbour's home for them when they are away or at work, as a favor. Under Block Watch that watchfulness is broadened and becomes more systematic. All residents on a block get to know each other through participation and communication to keep an eye out for each other

**Block Watch involves being alert** as part of your everyday life. For example, when you go to a window to close the drapes, take the time to look around the neighbourhood. Ensure everything is as it should be. Talk to your neighbours to keep them aware of current crime prevention techniques and news of local crime trends.

**The Program involves two commitments:** the first is to be concerned about your neighbour's property as you would your own. The second is to report suspicious or criminal activity to the Police and to your neighbours.

## What Block Watch Isn't

**Block Watch does not require** you to perform special tasks or go to a lot of meetings.

**You do not patrol** the neighbourhood or chase burglars.

**You aren't required** to live in your neighbour's hip pocket. You can still conduct your life in privacy.

**Block Watch doesn't require** that you be any friendlier than you want to be.

**Block Watch isn't just** for homeowners. The tips and techniques are equally valuable to tenants.

*Crime is a community problem that requires community response!*

## *Aims & Objectives of the Program*

- ✓ Reduce residential crime
- ✓ Improve Police / Public relations by "working together"
- ✓ Establish a sense of community within neighbourhoods
- ✓ Make our communities a better place to live, work and raise our children

### **As a Captain or Co-Captain:**

You **ARE** ...

- a neighbourhood communication consultant.
- the liason between your *local* Police department and your membership.

You **ARE NOT** ...

- the neighbourhood patrol.
- responsible for the security of your neighbours.
- expected to give up any privacy.

# Running Block Watch

---

**Q: How much time does being a participant take?**

**A: It really only takes seconds to look up & down your street, alley or at the school or park.**

**The primary function of the Block Captain** is to set up communication between neighbours and serve as the link between Block Watch participants and the Block Watch office. The Block Watch Captain or Co-Captain is not responsible to keep crime off the block, to patrol the area or be responsible for everyone's house keys when they are on vacation.

## Captain & Co-Captain Responsibilities

Serving as a Captain is not time consuming and you do not have to be home at all times to volunteer. Captain and Co-Captain don't have to perform all their duties alone.

### Ask others on the block to help out when necessary

Before becoming a Captain or Co-Captain you must undergo a security clearance. You must also undergo training (where most Captains or Co-Captains receive this manual). If you haven't completed these steps, please contact your Block Watch office.

## Draw Up a Map & Participant List

You are not officially on the Block Watch Program until the Block Watch office receives a copy of your map and participant list. See page 7 for instructions on this process.



## Organize at Least One Meeting Per Year

Neighbours meet to create a sense of 'community', and to also create a common bond with one another regarding crime prevention. Every meeting should be considered as important as the first! Block Watch groups should meet formally at least once a year to renew acquaintances and meet new neighbours. It's also useful to review block problems and find solutions. Occasionally, new Captains and Co-Captains can be selected at these meetings.

These meetings can also be used to educate the block about the program and pass on security advice received from the Block Watch office.

## Conduct Telephone Fanouts Or Use Email



Fanouts are a method of contacting neighbours to inform them of any incidents, crime trends, suspicious activity and updated Block Watch information.

It is the Captain's and Co-Captain's responsibility to keep everyone informed and aware of what is going on in your neighbourhood.

The Block Captain may wish to set up a telephone tree. It is a system where Block Watch members are assigned to call other members with information. This lessens the burden on the Captain or Co-Captain and helps speed up communication.

Email communication is as simple as a touch, set up "group email".

# Captain & Co-Captain Responsibilities

---

## Distribution of Newsletters

Newsletters are an important communication tool. Deliver them to participants personally. This gives you another opportunity to exchange information with them. It also helps you keep tabs on what's happening on your block.

If you do not have your own newsletter, there is one available on the Block Watch website: [www.blockwatch.com](http://www.blockwatch.com)

## Distribute Manuals & Equipment

Decals, manuals and other handouts are available at no cost. Block homes can borrow an engraver from their coordinator to mark their valuables. After a participant has engraved their valuables, they can obtain Block Watch decals from their Captain or Co-Captain. The decals are displayed at entrance ways to show that valuables are marked for police identification.



## Communication with the Block Watch Office

Stay in contact with your Block Watch office. Ensure that they have an updated Block Watch map, with current names and phone numbers.

The office will also photocopy your maps and lists, if need be, so you can distribute them to your block. Report any crimes or suspicious activity that occurs on your block to the Police first, ask for a file number and then advise the Block Watch office.

## Proper Communication

Contact new neighbours who move onto the block, invite them to join the program and forward information to them. Encourage participants to inform you when they witness suspicious activities, crimes or any other block problems.

Remind them to call the Police first, ask for a file number then advise the Captain or Co-Captain, who will in turn inform the Block Watch office.

## *Practise Crime Prevention Strategies*

### **Provide a good example to your block by practising good crime prevention strategies in your home:**

- Engrave valuables and display decals. (Engraved property is more difficult to pawn.)
- Take photos or videos of items you can't engrave.
- Leave front and rear outside door lights on all night. (Property criminals do not like to be seen.)
- Secure doors and windows each time you go out.
- Examine and modify landscaping and shrubs to make your home more visible from the street. This includes eliminating potential hiding places for criminally-minded individuals.
- Lock your cars and bring valuables inside. Do not leave **ANYTHING** in your vehicle.
- Put away tools, ladders, etc.
- Tell the neighbours when you will be away.
- Watch for suspicious activity or strange vehicles.
- Call Police when necessary. 911 for emergencies or your local non-emergency number if your area has one.
- Call your Block Watch office to discuss crime prevention measures.

# The Block Watch Map

## Create a Block Watch Map

### Here's how:

Keep it simple and don't worry if you are not an artist. Make your map functional and clear and concise. Mark the street names and house numbers on it. Also, include the names and phone numbers of the block members or attach a list.

Make the map suitable for everyday communication among block members. Be sure it's easy to use in the event of an emergency. Also, put compass directions on the map.

Include important phone numbers, such as emergency and non-emergency numbers of police fire and ambulance (if applicable). Add the Block Watch office number and your block identification number for reference.

Be sure to update the map regularly and send a copy to both the Block Watch office and block members. Date the map to indicate how current it is. Keep your map near the phone, but out of sight. If it got into the wrong hands, it could cause you and your block a lot of problems.

## Map Options

Some block members may not wish to disclose their phone number to other residents. In these cases simply write *UNLISTED*.

If they permit, list their business phone number instead. Check to see if these participants are willing to give their unlisted numbers to you and the Block Watch office for message fan-out and emergency purposes.

Remind them that Captains and Co-Captains are security-cleared and reassure them that the number will be kept confidential.

If your block is uncomfortable with a particular neighbour being part of your Block Watch (and subsequently having a map and list of participants), it is certainly permissible to exclude

that neighbour. For example, this neighbour might be someone who is creating the problems on your block that you are trying to eliminate.

You can include names and street addresses of the people in the homes that back onto your block. Record this information on member's personal maps. It need not be added to the block master copy that's kept at the Block Watch office. This can be helpful if block members observe suspicious activity occurring on the next block over.

### Consider including:

- Business or work numbers
- Cell phone numbers
- The names and ages of block children
- Block members' vehicles, including make, model, plate number and colour
- Alarms that are installed on the block
- Number of pets

**Block Watch Map** Block # 4

Police Emergency phone: \_\_\_\_\_

Police Non-Emergency phone: \_\_\_\_\_

Block Captain: Bashir Barry

Co-Captain: Red Inglis

Date: January, 14 2011

412	Red Inglis 604-555-1041 <b>Co-Captain</b>
410	Cal & Dee Young 604-555-1631
408	Quan & Ho Lee 604-555-6921
406	Bashir Barry 604-555-2761 <b>Block Captain</b>
404	Helen Reeve 604-555-5044

Ridge Dr

411	Sam & Mary Smith 604-555-1791
409	Joe Pitre 604-555-2717
407	John J. Rankin 604-555-98075
405	Not Participating
403	Sal Rosie Stone 604-555-8299

96th Ave

**N**



# Block Watch Program Dynamics

---

## The Block Watch Meeting

A neighbourhood meeting is the first step in creating a Block Watch community. Your Block Watch Captain will introduce you to your neighbours and the Block Watch team.

## The Block Watch Map

The neighbourhood map is important to the Block Watch Participants because it identifies all the homes on your block, with contact names and phone numbers for cases of emergency.

## Reporting a Crime or Suspicious Activity

The Police will need all the details that you can give them. Write down the person's sex, approximate age and height, the colour of clothing such as jacket, shirt, pants and shoes. Keep your original notes and give a copy to Police.

In the case of suspicious vehicles, look for the licence number, the colour, body style (e.g. two or four door sedan), and any unusual characteristics such as a loud muffler, wide tires, rust or missing parts and bumper stickers.

**Please refer to form on page 20.**

### ***Make the Call Count***

- Stay calm
- Stay on the phone until told to hang up
- Let the operator control the conversation
- Give all the information requested

**You will be asked for some personal details, including birth date. This information is used to positively identify you.**

## How Calls are Handled

All calls are handled on a priority level and divided into two basic categories:

### **Emergency Calls - 911**

These include crimes in progress, such as break-ins, vandalism, and situations where the suspect is still present. The Police are dispatched on a high priority to these calls.

### **Non-Emergency Calls - A regular phone number that is available in most communities**

These are situations in which the crimes have already been committed, and suspects have left the scene. Police are dispatched to these calls based on availability of manpower - be sure to tell the operator whether or not you would like Police to attend your residence.

Always obtain a file number for reference purposes.

### **Report All Crimes or Suspicious Activity Even if "Minor"**

For example - theft of garden ornaments or lights. Police and your Block Watch office need to know what's happening in your neighbourhood. A Block Watch warning message could be sent by the Block Watch office to you, and other neighbourhoods.

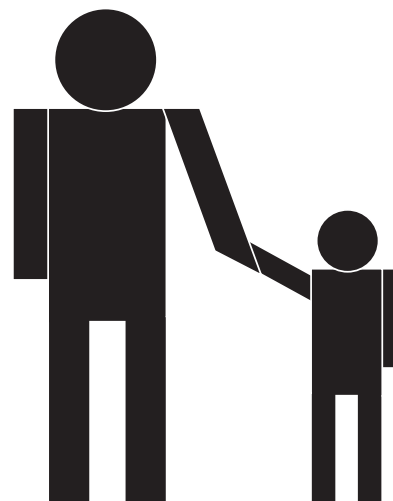



# Safer Communities

**The Block Watch Program** is not a new concept. It was introduced in Seattle in 1973, and since then it continues to combat local crime in communities throughout the modern world.

The concept is simple... neighbourly concern.

Block Watch is a volunteer program consisting of a Block Watch Captain, a Block Watch Coordinator and your local Police.

This booklet was prepared to assist citizens interested in organizing a local Block Watch Program. The Program was created in an effort to decrease residential break-ins through organized neighbourhood participation.

This program is successfully operating in many North American communities, and because it functions with the organized involvement and cooperation of community members, it is a proven crime deterrent. Community members are the key factor to safer communities.

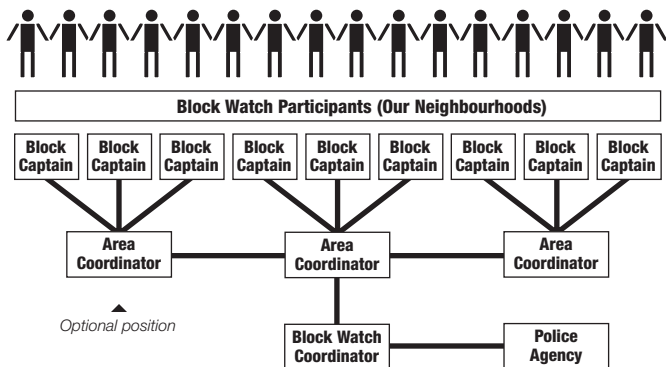

## The Procedure

### 1. Watch for Suspicious Activity

The success of the Block Watch Program relies on the prompt reporting of all suspicious activity. Many neighbourhood crimes have been prevented because alert neighbours have made a call to the Police.

### 2. Call Police

For emergencies dial **911**



### 3. Call a Block Captain

The Block Captain will then alert:

- Assigned neighbours
- Assigned Area Coordinator (if this option is available in your program)
- Your Block Watch Coordinator

### 4. Use Email

Communicate efficiently via email.



### Examples of suspicious activity that should be reported:

- Slow moving vehicles... *possible burglars casing homes*
- Unknown vehicle loading valuables... *possible break-in in progress\**
- Property carried by persons on foot... *possible stolen property\**
- Persons going door to door... *possible burglars casing homes*
- Stranger in backyard... *possible burglar looking for an entry point\**
- Door/window forced open... *possible break-in in progress\**
- Many visitors, coming and going at all hours... *possible drug activity*

(Contact your Block Watch office for more information on suspicious activity)

\* Requires emergency call to 911



# Holding a Block Watch Meeting

Here are some things to remember when preparing for your Block Watch meeting:



- Determine where the meeting will be conducted. It can be held at the Captain's or Co-Captain's home or at another designated home. You can also look into holding it at a local community facility, such as a school or community centre.
- Speak to everyone who you would like to attend. Explain that you are the Block Captain, who has been trained to organize Block Watch in the neighbourhood. Advise them on when and where the Block Watch meeting will be held. You can ask your coordinator to attend your meeting.
- A Block Watch video can be downloaded from the Block Watch website @ [www.blockwatch.com](http://www.blockwatch.com)
- The block meeting is the best time to compile data for the block map and participant list. Distribute manuals, handouts, etc. Encourage everyone to write down any suspicious activity when they witness it. This information can be invaluable to a police investigation.
- Encourage everyone to mark their valuables for identification or take photos of jewellery and artwork.
- Remind people to use the Suspect Identification Form on page 20. Make arrangements to circulate the engraver and remind people that they will receive their decals once their valuables have been engraved.
- Implement a telephone or email fanout system.
- Don't be disappointed if some neighbours don't show up. This is quite common and doesn't mean that they are not interested. After the meeting, contact those that did not attend and encourage them to participate and collect the missing data for your map.
- Distribute the map and participant list to everyone. After the meeting, please call the Block Watch office and let them know how the meeting went. If you need further assistance, this is a good time to ask.
- Make sure to send updated maps to your Block Watch office.

# Holding a Block Watch Meeting *Continued*

---

## Introduction

Provide everyone with name tags. Introduce yourself and ask everyone to introduce themselves and identify where they live.

Thank everyone for coming and then briefly explain why you have taken the steps to organize Block Watch. Ask the participants to share information with the group about any problems they have encountered on the street or in the complex.

## Block Watch Video & Handbook

Show the video from the Block Watch website. Give a copy of the Block Watch manual to everyone and point out that it provides general information about home security. Suggest that they call the Block Watch Office if they need further help with home security.

## The Engraver

Discuss the engraver and why it is useful in protecting valuable belongings. Tell them that they can borrow it for three days at a time. Reserve an engraver with your coordinator or purchase one for your group. Tell them that door decals are available to them once their contents have been engraved. Remind them to engrave their drivers licence number. **DO NOT** use your social insurance number. Use your B.C.D.L. or B.C.I.D. *only*.

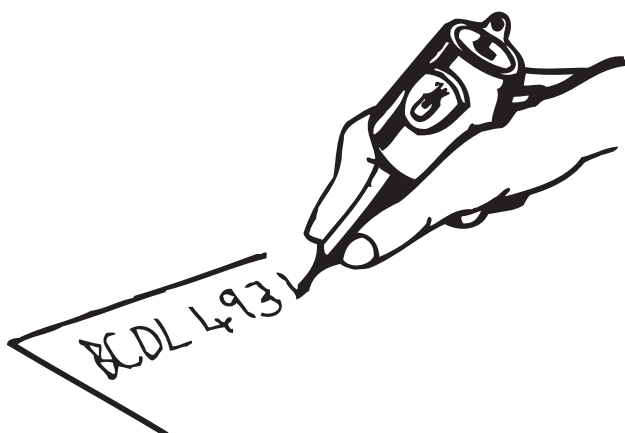

## Home Insurance

Discuss home insurance issues. Tell them that some companies give discounts to members of Block Watch.

Suggest that they photograph or video-tape valuables and make an inventory of their household items. Keeping a file of sales receipts is also a good idea. All these precautions are useful during an insurance claim.

## The Block Map

Explain why and how the block map is used.

Complete the map at the meeting. Remind everyone to keep it in a handy place that's out of sight. Tell participants to ensure that their house numbers are lit and are visible from the street. Tell them this also helps emergency vehicles find their home. The map should be updated annually.

## Newsletters

Tell block members that they will receive the newsletters from the Captain or Co-Captain. Explain its purpose.

## Calling the Police

Tell participants to obtain a police file number if they have to call the Police. This will help in the future if they want to follow up on the case.

## Wrap Up

If you do not have a Co-Captain, ask for volunteers. Decide how often your block should meet. Answer questions and deal with any other business at hand.

# Maintaining Block Watch

---

**For information to be useful, it must be shared. Communication is the key to maintaining the Block Watch Program. Here are several ways you can communicate effectively:**

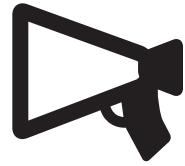

## Personal Contact

Hand delivered hard copy newsletters should be delivered in person so that Captains and Co-Captains can have added contact with participants and exchange additional information.

*Being alert to crime and its prevention is the responsibility of everyone on the block*

## Contact With Your Office

The Block Watch office tries to maintain ongoing contact with all Captains on a regular basis. In larger programs, Area Coordinators assist by acting as a liaison between a number of Captains and the Block Watch office.

## Message Fanout System

The message fanout system is a method of communicating information to your block.

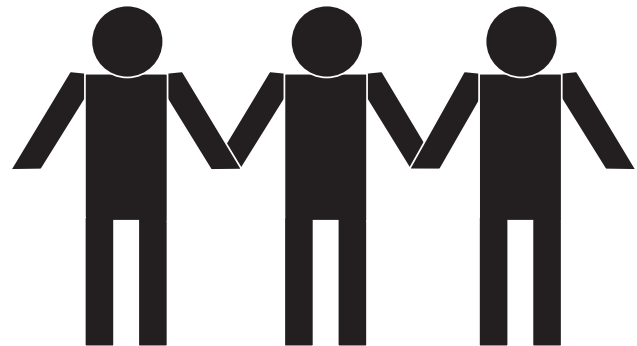

### Benefits of the Fanout System include:

- Information of interest to Block Watch participants can be quickly transmitted and communicated. Information regarding crime trends occurring in a specific area can be distributed to participants to raise awareness.
- Descriptions of suspects active in residential break and enters or in vehicle thefts can be communicated.
- Captains and Co-Captains must keep track of those participants who do not have an email account, and deliver a hard copy or contact them by phone.
- If any message is relayed to the Captain or Co-Captain from participants or the Block Watch office regarding suspicious activities or occurrences, then the fanout system must be implemented as soon as possible. It's a system whereby the Captain or Co-Captain (or designated block members) call or email block participants to relay the information.

# Dwellings Other than Houses

**Block Watch works particularly well in apartments, townhouses and mobile home complexes.** In these dwellings, it is organized in a manner similar to how residential streets are set up. However, a few adjustments are required:

A Complex Coordinator or Area Coordinator can be responsible for the organization and implementation of the Block Watch Program for the entire development. The Coordinator works with all the Captains, but is usually the person that acts as the liaison with the Block Watch office. You may still have Captains and Co-captains.

An overall map of the development is usually used with the development being broken into “blocks” of a convenient size for the Captain to manage.

**Examples of this are:** one Captain per floor, one Captain per six units, or perhaps a committee similar to your strata council.

The map of the development should be included along with the individual maps of the “blocks” to each participant and the Block Watch office. In lieu of maps, lists may be used if you feel this would be a more appropriate method to keep in touch with your neighbours.

## *A Few Things to Consider*

- Is there a resident manager who can be part of the Block Watch system?
- Are all entrances key controlled?
- Are the building and parking areas well lit at night?
- Do units have good deadbolt locks and peep hole viewers?
- Do you feel safe when alone in parking areas, laundry rooms, etc.?
- Will the manager allow you to re-key the locks if they are not adequate?
- Is there a security garage door or gate?
- Contact your landlord or manager and obtain his/her cooperation regarding the installation of any new home security devices.
- Use “M. Smith”, not “Mary Smith”, on the intercom board or mailbox. This is so that you don’t let strangers know you live alone. It also conceals your gender.
- Don’t leave notes on the door or buzzer panel.
- Report all suspicious activity to the Police first, then to the manager and all block participants. Don’t forget to call the Block Watch office.
- Don’t hold the door or gate open for strangers, or “buzz” them in if they ring your unit. Have them ring the manager.
- Instruct your children on the correct procedure for admitting people and calling 911.
- Lock your door even if you are leaving your unit for only a few minutes.
- Report all burned out lights to the manager and insist they be replaced immediately.
- Be sure to secure all doors and windows. The same goes for those in the garage, whether they are attached or not. Remember, garages are a good hiding place for a burglar.
- Make arrangements to provide access to emergency response personnel when a 911 call is made.
- If your intercom number is different than your suite number, remember to tell the operator taking your call.
- Remind residents to be sure the gate is closed after they enter or exit underground parking.
- Numbers on intercoms should be coded, so they don’t match the suite number.
- Secure buildings may wish to provide police with a master entry code, fob, or key in case of emergency. Ask your coordinator about this.

# Property Identification - Home Security

---

## Property Identification

Burglars seldom steal things for their own personal use. They steal items that are portable, easily converted to cash - and most particularly, items that cannot be identified as to ownership.

Property identification will discourage a burglar from breaking into your home if all personal property is identified, as this creates a high risk for the thief. Here's how it works:

Police agencies have immediate national and international communications via computer. Within seconds, Police everywhere will be given the description of properly identified property. Proper identification is essential however, and that is where you can work together with your Police.

1. Obtain an engraving pen for your block/neighbourhood, and let the Block Captain keep track of it. You may also want to purchase your own engraver.
2. Engrave all your valuables with your B.C. drivers licence number.
3. Photograph or video tape items you don't or can't mark, such as jewelry, art and delicate glass. Include a ruler in the photo/video to visually determine comparative size.
4. Use the Property Inventory chart provided (see page 18 & 19) to help record all items.
5. After all items are marked, obtain Block Watch stickers from your Block Captain.

## Home Security

Burglars look for opportunities - points of entry - to get into your home. They quickly take what they want, and leave.

The facts are, that an overwhelming number of break-ins are executed with little or no force,

and **CAN** be prevented. Keep doors and windows secure.

The best way to prevent burglary is to eliminate opportunities. By making your home more secure, burglars must spend excessive time and create more noise than they're willing to risk.

**Outside Your Home** - Home security starts where the burglar starts - on the **OUTSIDE**. Most burglars are adept at seeking external "weak spots" which more often than not, reflect the overall quality of your home's security.

**Shrubbery** - Shrubbery offering concealment near entries or windows should be trimmed to eliminate hiding places. Basement windows are a common entry point, and often hidden by shrubbery. These windows should be replaced with unbreakable lexan or plexiglass, or window security film. You could also install decorative security bars. *Be sure to provide an appropriate Fire Exit if using bars.*

**Lighting** - Front and back porch lights should be kept lighted from dusk to dawn - well lit areas deter burglars. High, or caged vandal-proof lighting is preferable. Consider motion detector lighting for driveways, carports and walkways.

**Tools and Ladders** - Keep all tools and ladders securely locked and out of sight. Burglars could use these tools to break into your, or your neighbour's, home.

**House Numbers** - Be sure your house number is clearly visible from the street, especially if you have a long driveway. Be sure it can be seen at night and that no plants grow over it.

Emergency vehicles will be able to identify your home easily and quickly in the event of an emergency.

**Lane Access** - Ensure that this area is also well lighted and secure. House numbers should also be easily visible from your lane.



# Home Security Tips - Doors & Locks

---

## Exterior Doors

On most homes, an exterior door often provides easy access due to an inadequately secured door frame, or a wood frame that is weakened due to weather, ageing, etc. When such a door is kicked, the frame usually gives way, allowing the burglar to enter.

Check the condition of wood frames. If worn, have a new frame made. Anchor the frame to the wall studs by removing short screws used to secure the strike plate and hinge plates, and replacing them with 3" - 4" screws. This should be done for all exterior doors.

In terms of vulnerability, the following doors pose the greatest concern because they allow easy access to locks and knobs.

### Hollow Core Doors

Comprised of a wooden frame with two thin sheets of plywood glued to either side, and usually filled with corrugated cardboard. Access can be gained by punching through, or easily cutting a hole in the door.

### Panel Doors

Basically solid in the main construction. However, some panels may be thin and easily punched or kicked in.

### Doors with Upper Glass Panels

The upper half of these doors contain a thin pane of glass which can easily be broken, and entry gained.

### Doors with "Side lights"

#### SOLUTIONS:

1. Reinforce existing doors. You can do this by measuring the outside dimension of the door. Allow for knobs, locks, etc.. Purchase a 1" thick sheet of marine grade plywood and attach to the outside of door with glue or screws.

2. Replace the glass pane with a durable plastic product, or treated glass. (Refer to the section on Glass Window Alternatives - pg 17).

3. Replace ALL exterior doors with solid core doors. Solid lumber or steel is recommended. Be advised that some "solid core" doors are actually constructed of particle board and are less durable.

### Peephole

Install a wide angle (180°) peephole in the entrance doors so that visitors can be viewed without opening the door. It should be placed at a height convenient for all family members.

Also, consider installing an intercom system so you may communicate with callers without opening the door.

### Night Chains

Do not rely on night chains. They can usually be broken with little effort. Consider an alternative, such as the wedge-stop, ensuring that both your door and the stop are of solid construction.

## Locks

### Key-In-The-Knob Locks

This is a very common lock with a keyed mechanism built into the knob. It is easily defeated by breaking, or by wrenching off the knob.

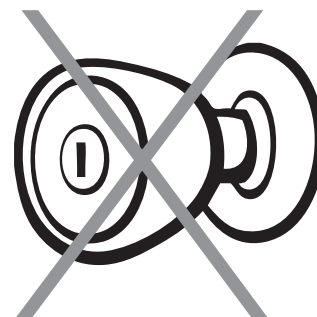

**DO NOT USE THIS KIND OF LOCK ON EXTERIOR DOORS.**



# Home Security Tips - Doors & Windows

## Deadbolt Locks

A deadbolt lock should have a 1" to 1½" throw (see illustration), and be affixed securely to the door with hardened steel screws. They are available as **Single Cylinder** with a thumb turn on the inside and a key lock on the outside. Install on all solid or reinforced doors where access to locks and knobs cannot be gained by breaking adjacent glass. Check to ascertain the depth the "throw" extends into the striker plate/frame. Ensure striker plates are installed using 2½" screws, extending into the framing, not just the door trim.

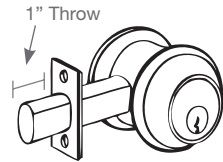

### Commissioner's Warning

**Locked doors must allow unrestricted exiting from a building. Doors with double cylinder locks (keyed both sides) are not permitted.**

Fire Commissioner  
Ministry of Municipal Affairs, BC

## Sliding Glass

### Doors and Windows

Secure the door or window using pins or dowels.

First, inspect the point where the inner and outer frames overlap. If you can drill without breaking the glass, drill a downward-angled hole completely through the inner frame and halfway through the outer frame. Insert a sturdy pin or nail snugly into the hole. Be sure that it is long enough to remove and re-insert if necessary). This method will prevent the door or window from sliding.

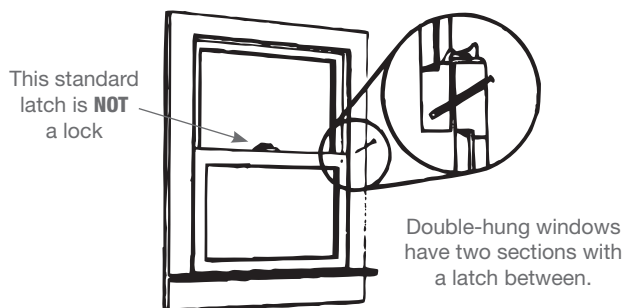

Sliding glass doors and windows are similarly constructed and share common security problems, although windows are by far the weakest link in the security chain. Both often have inadequate locking mechanisms that can be easily forced open.

Determine whether your door or window slides on an *inside track* or an *outside track*.

### Inside Track

If an inside track, install a snug fitting wooden or metal dowel into the bottom track, or purchase a "charlie bar".

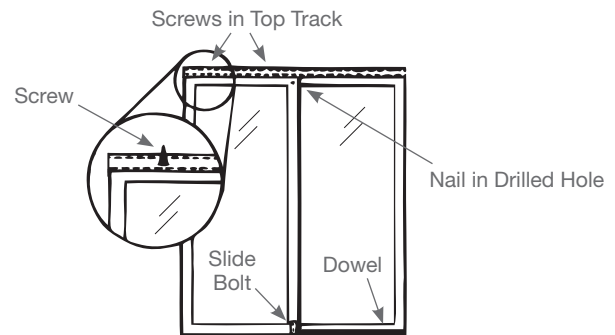

### Outside Track

If an outside track, obtain one of the many commercial, foot-operated locking devices, or install a slide bolt.

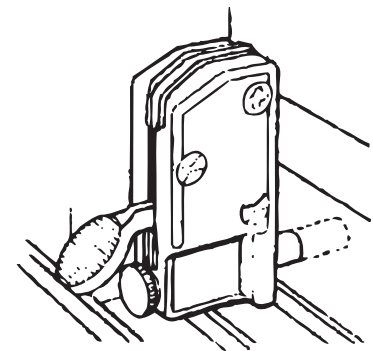

### Shims (Anti-lifting devices)

If your sliding door or window can be lifted out of the track, this means there is more vertical space than necessary. To prevent this from happening, use large-head sheet metal screws in the top track at both ends and in the middle. Adjust screws to fill the space and allow the door to freely slide. Commercial shims are also available.

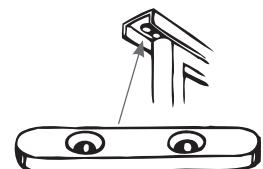

# Home Security Tips - Windows & Checklist

## Window Security

### Double-Hung Windows

These usually have a top half that can be lowered, and a bottom half that can be raised. A latch is situated in the center where both halves overlap.

Burglars gain entry by prying the latch and lifting the window. Or, they break the glass, reach in and undo the latch.

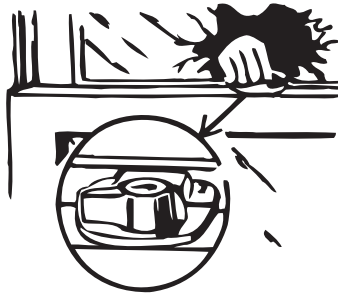

### Casement Windows

These windows swing open and are hinged at the top, side or bottom.

As with double-hung windows, entry is usually gained by breaking a small piece of glass near the latch and reaching through to undo the latch.

Keyed latch secures casement windows

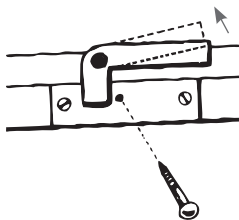
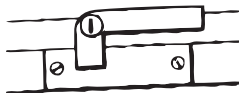

Screw prevents casement latch from opening

### Security Solutions

If the window is not being used as an emergency escape or ventilation, permanently seal the window with nails or screws. Replace the latch with a keyed latch or pin the windows with a nail or pin.

### Glass Window Alternatives

Plastic, treated glass, and security film are effective alternatives. Durable security film can also be applied on the existing windows. Consult a glazier for professional advice.

**Remember:** Security improvements are no guarantee to prevention of burglary. They “slow the burglar down.” Vigilance and working together as a watchful community will always be the best solution to crime.

Before you begin to improve your home security, identify entry points most likely to be used by a burglar. Do this by answering the following questions:

- Which entrances are hidden or out of view?
- If locked out of my house, where could I get in without much difficulty?

All those you identify should be secured. Your goal is to make entry more difficult for the burglar by forcing them to take more time and make more noise!

▶ **DO NOT compromise fire safety for security** ◀

You should have fire escape routes in your home; you and your family should have “fire drills” to ensure your safety, particularly if you have young children at home.

## A Final Checklist

- Are all your exterior doors strong enough to withstand excessive force?
- Are all exterior doors secured with a dead bolt lock that has a minimum 2cm (1”) throw
- Are all strike plates and frames for exterior doors anchored to the home’s main framework?
- Do all exterior doors fit snugly and are free of warping, cracks, and other signs of wear?
- Is there a wide-angle peephole/viewer on the main entrance?
- Are sliding glass doors and windows secure against force or being lifted out of the frame?
- Are high-risk windows (hidden, garage, basement, etc.) secured sufficiently?
- Are double hung windows secured with pins or extra locks?
- Do all windows have adequate locks in good condition?
- Are trees and shrubs trimmed to allow clear visibility around the perimeter of your home?
- Do you have timers to activate interior/ exterior lights in your absence?
- Are all entrances to your home well lit at night?
- Do you **ALWAYS** use your security devices?

# How Much Would You Lose?

A complete household inventory, record of insurance policies and credit cards will be of value to police and insurance adjusters if you suffer a burglary or other loss. Please take the time to conduct an inventory **TODAY!**

**Note:** you may use the greyed suggestions below or overprint your own - **KEEP IN A SECURE PLACE**

LIVING ROOM		FAMILY / REC ROOM		MASTER BEDROOM		3RD BEDROOM / DEN	
Sofa(s)		Chair(s)		Bed(s)		Bed(s)	
Chair(s)		Curtains		Chair(s)		Chair(s)	
Lamp(s)		Lamp(s)		Bedding		Bedding	
Table(s)		Table(s)		Night Table(s)		Night Table(s)	
Stereo		Stereo		Dresser		Desk	
TV		TV		Bench		TV / Stereo	
PVR		PVR		Bureau		PVR	
Rug/Carpet		Desk		Mirror		Computer	
Art		Rug / Carpet		Lamp(s)		Monitor	
Curtains		Art		TV		Printer	
Piano		Other		Other		Other	
Other		Other		<b>TOTAL</b>		<b>TOTAL</b>	
Other		<b>TOTAL</b>		<b>2ND BEDROOM</b>		<b>YARD / GARAGE / STORAGE</b>	
<b>TOTAL</b>		<b>KITCHEN</b>		Bed(s)		Tools	
<b>DINING ROOM</b>		Table		Chair(s)		Vehicle(s)	
Table / Chair		Dinette		Bedding		Sports Equipment	
Cabinet		Stove		Night Table(s)		Lawn Mower	
Buffet		Fridge		Dresser		Ornaments	
Rug / Carpet		Dishes		Bench		Art	
Drapes		Cutlery		Bureau		Antiques	
Appliances		Utensils		Mirror		Other	
Silverware		Pots / Pans		Lamp(s)		Other	
China		Elec. Appl.		Rug / Carpet		Other	
Other		Other		Other		Other	
<b>TOTAL</b>		<b>TOTAL</b>		<b>TOTAL</b>		<b>TOTAL</b>	

# How Much Would You Lose?



<b>CREDIT CARDS AND BANK CARDS</b> (Keep this section in a safety deposit box or other high security location)			
Card Type	Card Number	Expiry Date	Credit Limit
<b>OTHER VALUABLE PROPERTY</b>			
Item Description	Make / Model / Type	Serial # / Identifying Mark	Value
<b>INSURANCE POLICIES</b>			
Company	Policy #	Amount	Expiry Date

# Suspect Identification Form

Keep a pen and this form handy to make an accurate record of events, should you be a witness to a crime in your neighbourhood. Fill in all blanks, and keep in a safe place until requested by police for their reports. This information could be instrumental in the apprehension, or conviction of criminals in a court case. **Keep the original**, as copies are inadmissible in court!

**NEVER intervene or attempt to apprehend a criminal.**  
**NEVER put yourself at risk to obtain information.**

## When should I call Police?

For a **CRIME IN PROGRESS**: Call 911 immediately.

For **SUSPICIOUS ACTIVITY**: Call your local police non-emergency line.



<i>General Suspect Appearance</i>			
SEX		WEIGHT	
AGE		RACE	
HEIGHT		HAT	
HAIR		COAT	
EYES		SHIRT	
COMPLEXION		PANTS	
JEWELRY		SHOES*	
SCARS		OTHER	
TATTOOS / IDENTIFYING MARKS			

<i>Vehicle Description</i>		
LICENCE #		
COLOUR	MAKE	MODEL
BODY STYLE		DAMAGE / RUST
ANTENNA	BUMPER STICKER	WHEEL COVERS
DIRECTION OF TRAVEL (INCLUDING STREET AND COMPASS HEADING IF KNOWN)		

<i>Suspect's Face</i>	
	
ANY SPECIFIC FACIAL DETAILS	
DID THE SUSPECT SAY ANYTHING?	
TOOL / WEAPON CARRIED BY SUSPECT	

<i>Witness Information</i>
WITNESS NAME
WITNESS ADDRESS
PHONE #
DATE / TIME
WEATHER

\* Running shoes have distinct logos, i.e. the Nike "swoosh", Adidas "3 stripes", Converse "star". Police can use this specific description for a positive identification.









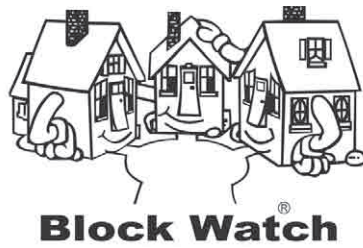

**VISIT US AT**  
[www.blockwatch.com](http://www.blockwatch.com)  
1-877-602-3358



Ministry of  
Justice